



ZEISS Interlock 1.4/85



Features

- Very fast f/1.4 aperture
- Precise manual focusing
- Robust full-metal construction
- Continuous aperture setting or click stop
- For industrial cameras up to sensor sizes of 24x36 mm or 41 mm line sensors
- High optical performance both at infinity and at 8.3 scale
- Features special screws to fix focus and aperture settings even in rough situations

Camera Mounts

Available with F mount or M42 screw mount



ZEISS Interlock 1.4/85

Technical Specifications

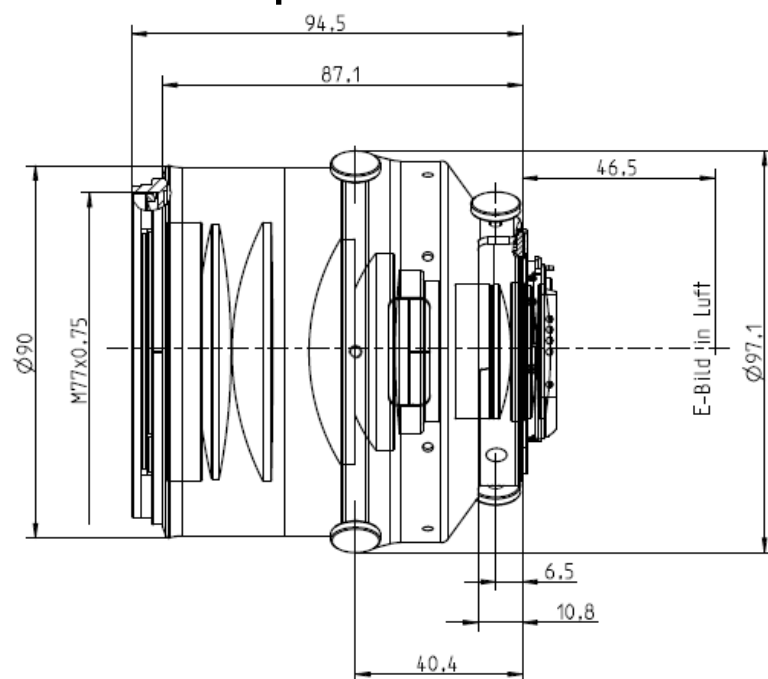

Focal length	85 mm
Aperture range	f/1.4 – f/16 (1/2 stop intervals or continuous)
Number of elements / groups	11 / 9
Min. working distance (object to sensor)	800 mm (2.62 ft.) – ∞
Min. free working distance	650 mm (2.13 ft.) – ∞
Angular field* (diag. / horiz. / vert.)	29 / 24 / 16°
Max. diameter of image field	43 mm (1.7")
Flange focal length	F-Mount: 46,5 mm (1.8"); M42-Mount: 45,5 mm
Coverage at close range*	area: 298 x 208 mm (11.7 x 8.2") line: 356 mm (14,0")
Image ratio at close range	1:8.3
Filter-thread	M77 x 0.75
Weight	1.277 g (2.8 lbs.)
Camera mount	F bayonet, M42

* referring to 35 mm format



ZEISS Interlock 1.4/85

Relative Illuminance*

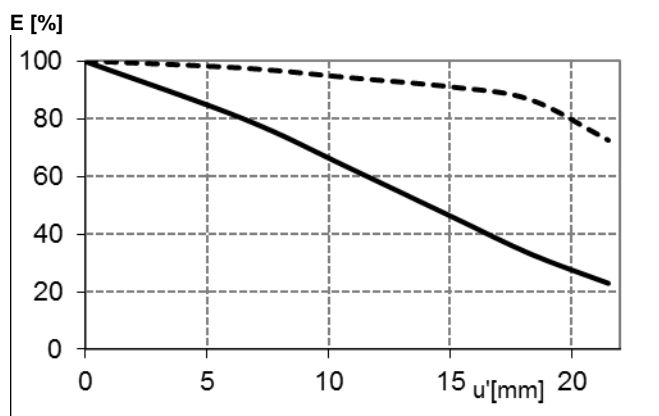

The relative illumination shows the decrease in image brightness from the image center to the edge in percent.

— f-number 1.4
--- f-number 4

Relative Distortion*

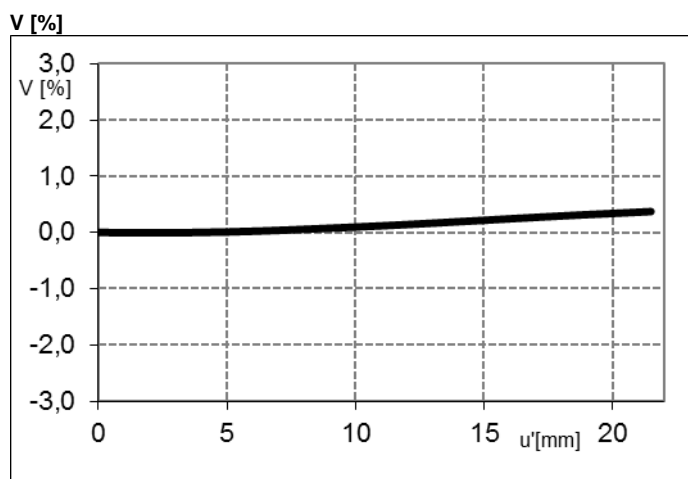

The relative distortion shows the deviation of the actual image height from the ideal one in percent.

*Data for infinite focus setting



ZEISS Interlock 1.4/85

MTF Charts*

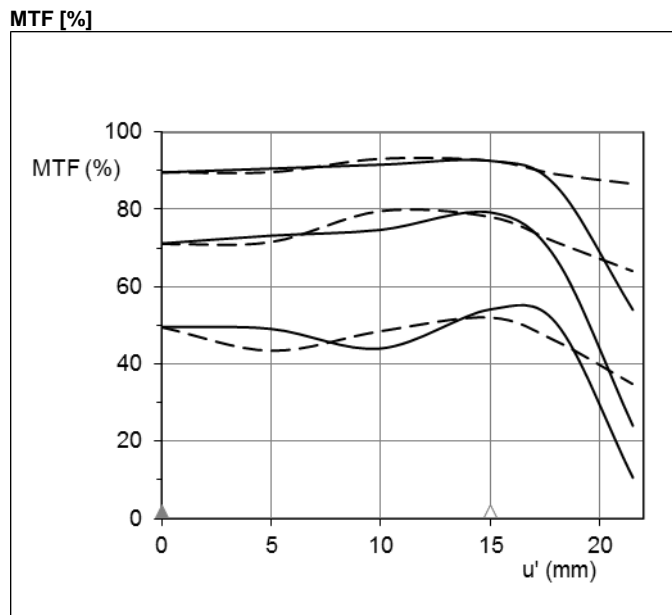

The Modulation Transfer (MTF) as a function of image height (u) and slit orientation (sagittal, tangential) has been measured with white light at spatial frequencies of $R = 10, 20$ and 40 cycles/mm.

f-number 1.4
— Sagittal
... Tangential

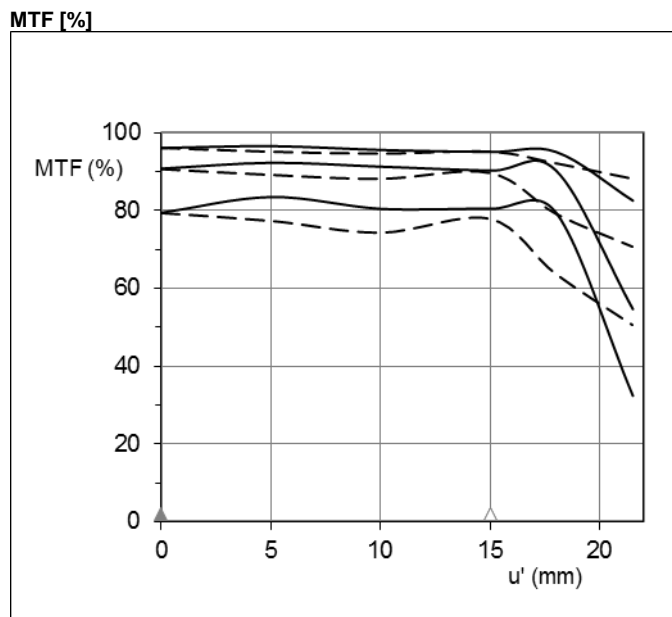

f-number 4
— Sagittal
... Tangential

*Data for infinite focus setting



ZEISS Interlock 1.4/85

Spectral Transmission

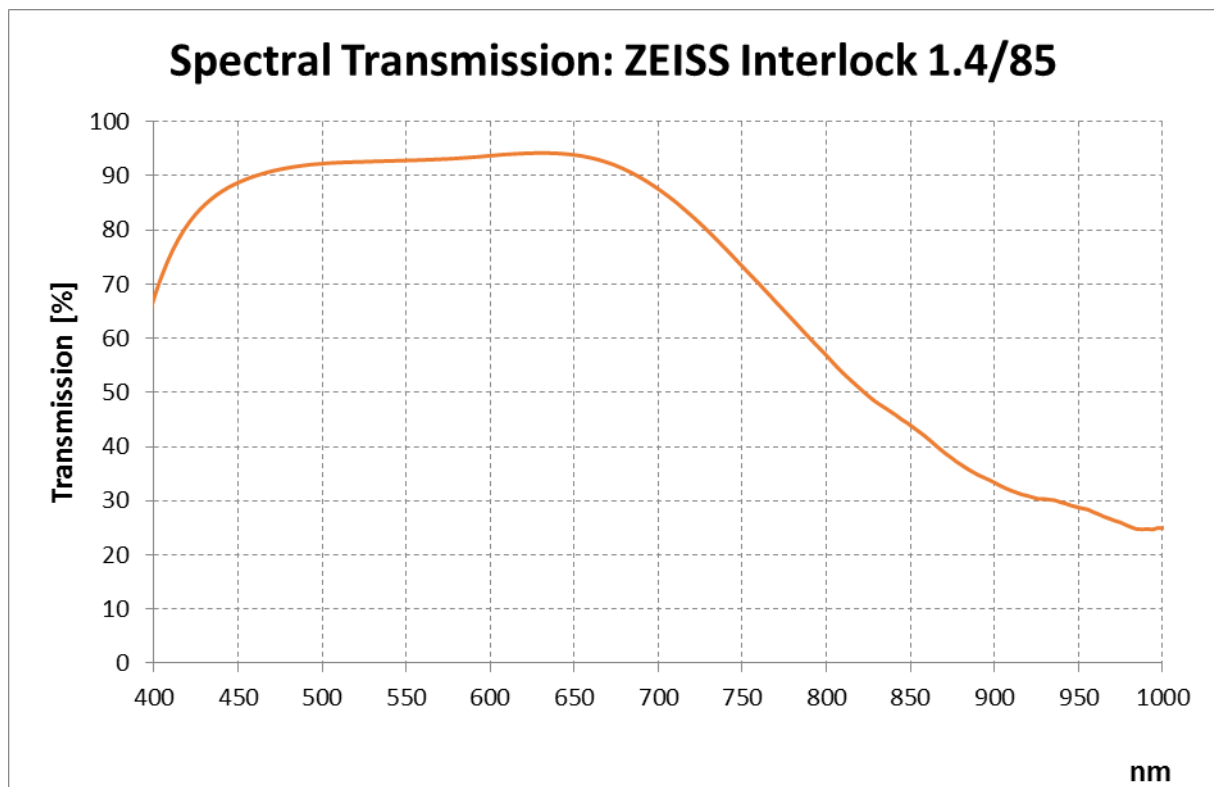



ZEISS Interlock 1.4/85

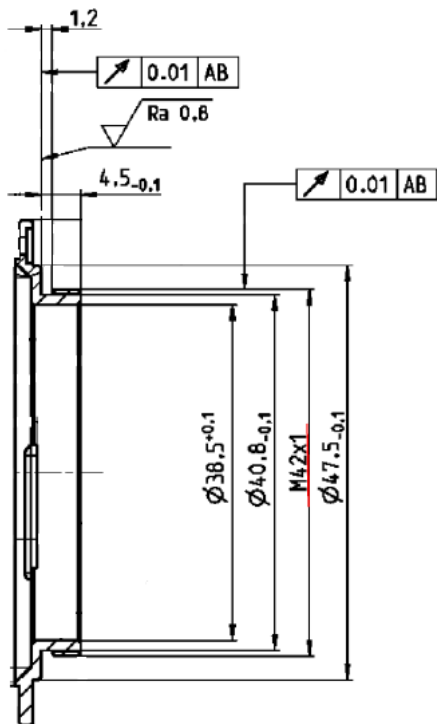

M42 Mount for 45,5 mm Flange Focal Distance

The diameter of the camera/lens adapter must not exceed 55 mm at the lens side!