



ZEISS Interlock 1.4/25



Features

- Very fast f/1.4 aperture
- Precise manual focusing
- Robust full-metal construction
- Continuous aperture setting or click stop
- For industrial cameras up to sensor sizes of 24x36 mm or 41 mm line sensors
- High optical performance both at infinity and at 1:4.6 scale
- Features special screws to fix focus and aperture settings even in rough situations

Camera Mounts

Available with F mount or M42 screw mount



ZEISS Interlock 1.4/25

Technical Specifications

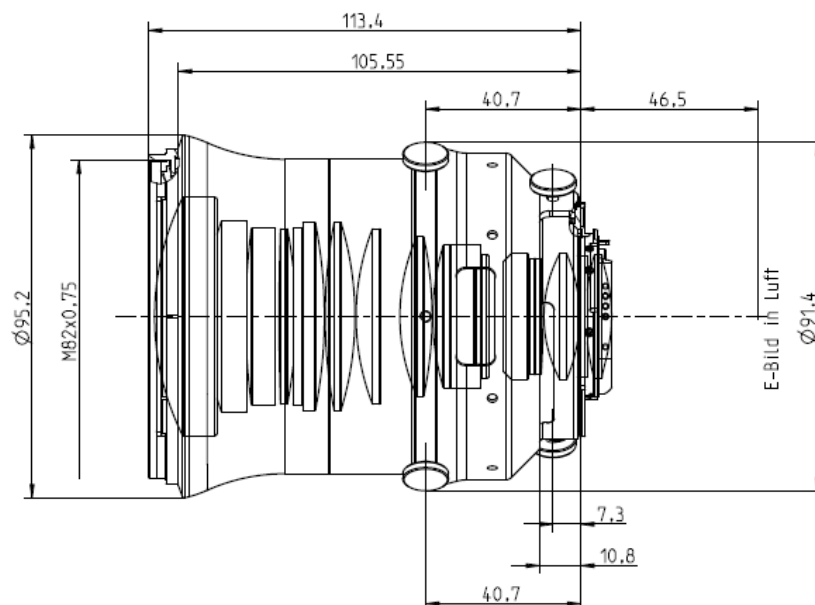

Focal length	25 mm
Aperture range	f/1.4 – f/16 (1/ 2 stop intervals or continuous)
Number of elements / groups	15 / 13
Min. working distance (object to sensor)	252 mm (0.83 ft.) – ∞
Min. free working distance	93 mm (0.31 ft.) – ∞
Angular field* (diag. / horiz. / vert.)	81,2° / 70,8° / 50,4°
Max. diameter of image field	43 mm (1.69")
Flange focal length	F-Mount: 46,5 mm (1.8"); M42-Mount: 45,5 mm
Coverage at close range*	area: 166 x 110 mm (6.5" x 4.3") line: 188 mm (7,4")
Image ratio at close range	1 : 4.6
Filter-thread	M82 x 0.75
Weight	1.218 g (2.7 lbs.)
Camera mount	F bayonet, M42



ZEISS Interlock 1.4/25

Relative Illuminance*

E [%]

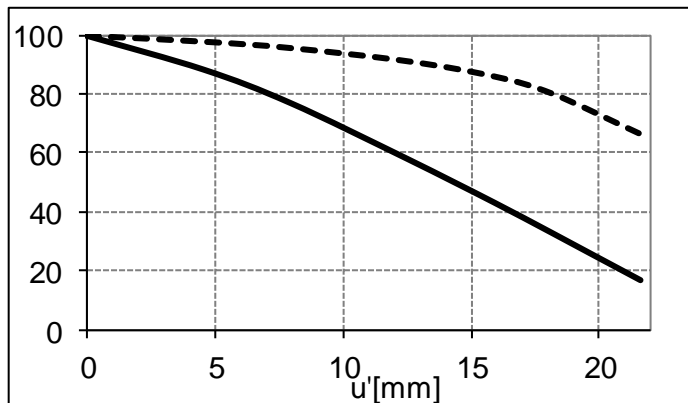

The relative illumination shows the decrease in image brightness from the image center to the edge in percent.

— f-number 1.4

--- f-number 4

Relative Distortion*

v [%]

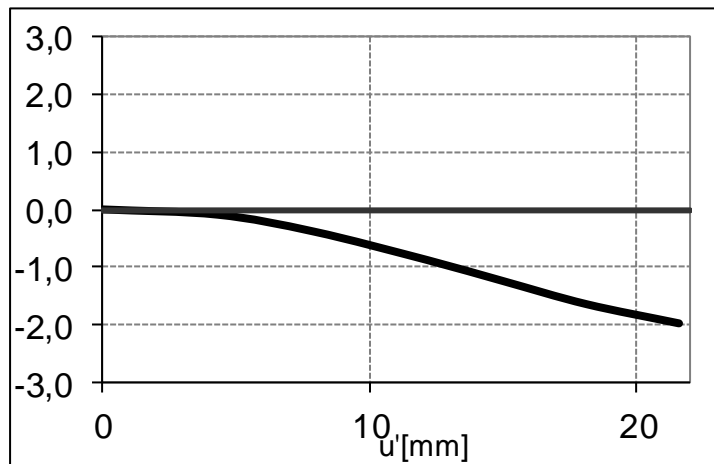

The relative distortion shows the deviation of the actual image height from the ideal one in percent.

*Data for infinite focus setting



ZEISS Interlock 1.4/25

MTF Charts*

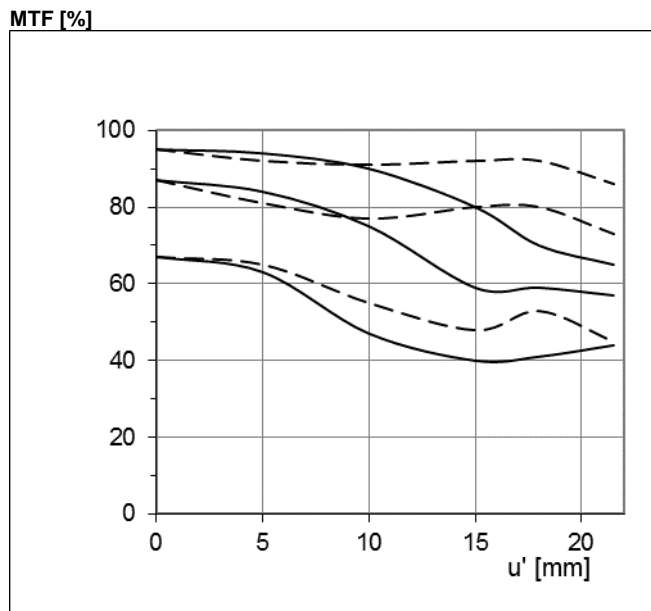

The Modulation Transfer (MTF) as a function of image height (u) and slit orientation (sagittal, tangential) has been measured with white light at spatial frequencies of $R = 10, 20$ and 40 cycles/mm.

f-number 1.4
— Saggital
... Tangential

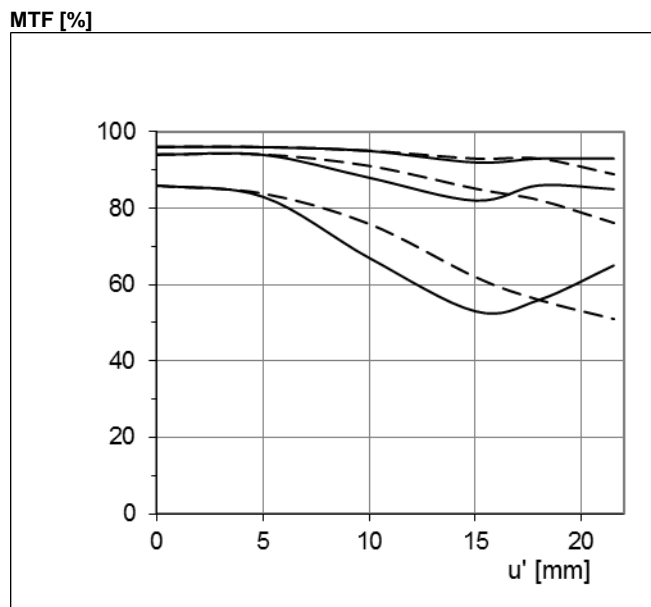

f-number 4
— Saggital
... Tangential

*Data for infinite focus setting



ZEISS Interlock 1.4/25

Spectral Transmission

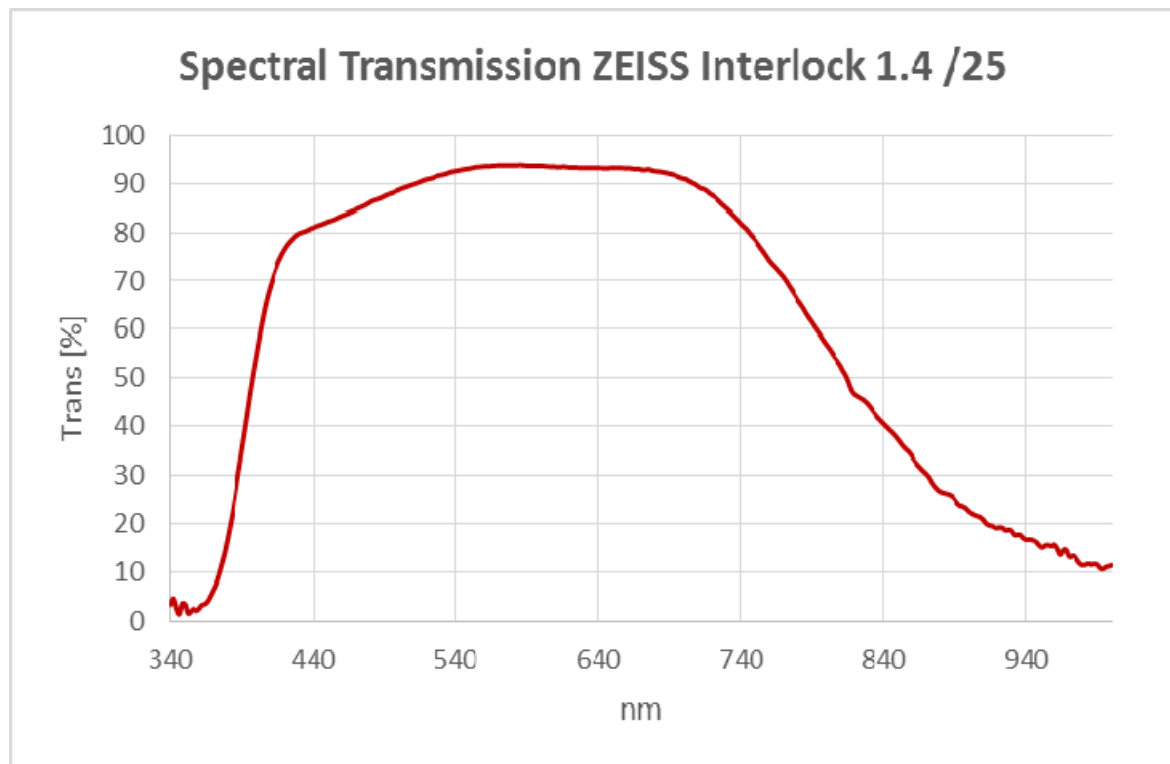



ZEISS Interlock 1.4/25

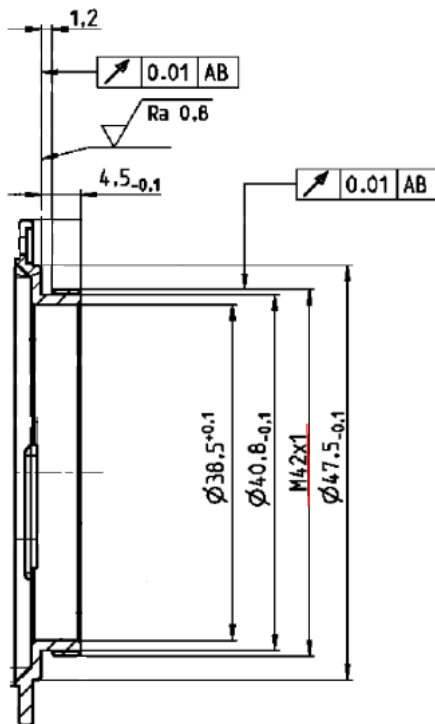

M42 Mount for 45,5 mm Flange Focal Distance

The diameter of the camera/lens adapter must not exceed 55 mm at the lens side!