



ZEISS Interlock 2.8/15



Features

- 110° angular field with highest optical performance
- Precise manual focusing
- Robust full-metal construction
- Continuous aperture setting or click stop
- For industrial cameras up to sensor sizes of 24x36 mm or 41mm line sensors
- For industrial cameras up to sensor sizes of 24x36 mm or 43mm line sensors
- Features special screws to fix focus and aperture settings even in rough situations

Camera Mounts

Available with F mount or M42 screw mount



ZEISS Interlock 2.8/15

Technical Specifications

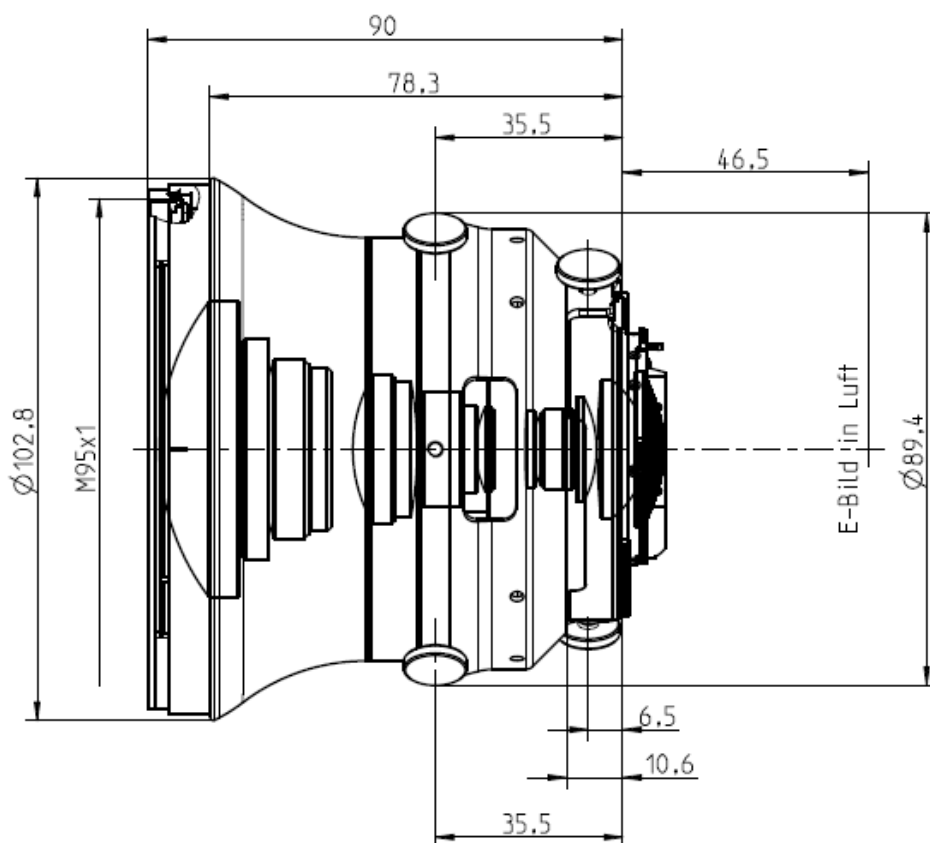

Focal length	15 mm
Aperture range	f/2.8 – f/22 (1/2 stop intervals or continuous)
Number of elements / groups	15/12
Min. working distance (object to sensor)	250 mm (0.82 ft.) - ∞
Min. free working distance	90 mm (0.29 ft.) - ∞
Angular field* (diag. / horiz. / vert.)	110 / 100 / 76°
Max. diameter of image field	43 mm (1.7")
Flange focal length	F-Mount: 46.5 mm (1.8"); M42-Mount: 45,5 mm
Coverage at close range	340 x 221 mm (13.4 x 8.7"), line 387 mm (15.2")
Image ratio at close range	1:9
Filter-thread	M 95 x 1.0
Weight	927 g (2.0 lbs.)
Camera mount	F bayonet, M42

* referring to 35 mm format



ZEISS Interlock 2.8/15

Relative Illuminance*

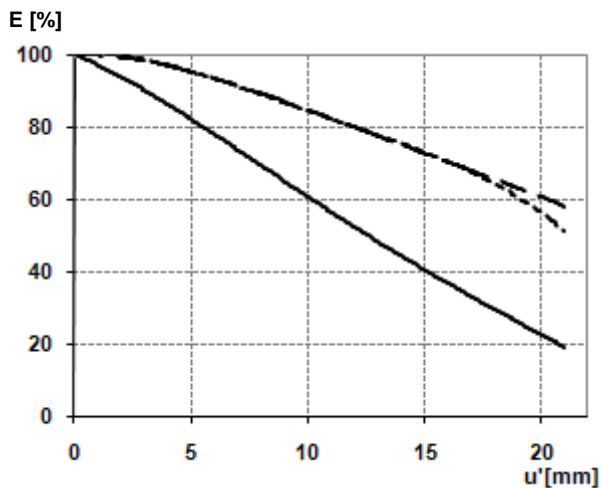

The relative illuminance shows the decrease in image brightness from the image center to the edge in percent.

- f-number = 2.8
- ... f-number = 5.6
- f-number = 8

Relative Distortion*

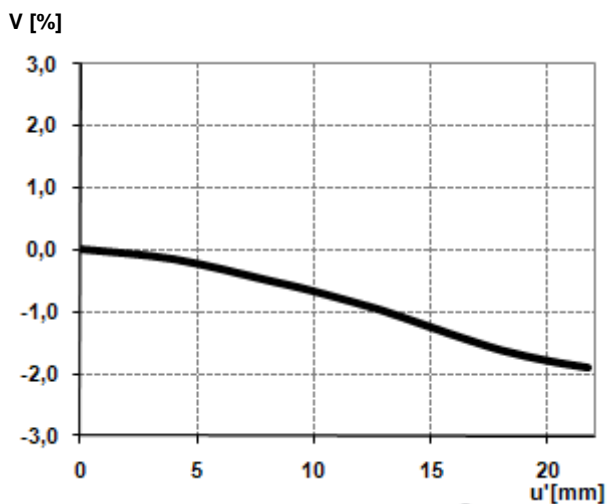

The relative distortion shows the deviation of the actual image height from the ideal one in percent.

*Data for infinite focus setting



ZEISS Interlock 2.8/15

MTF Charts*

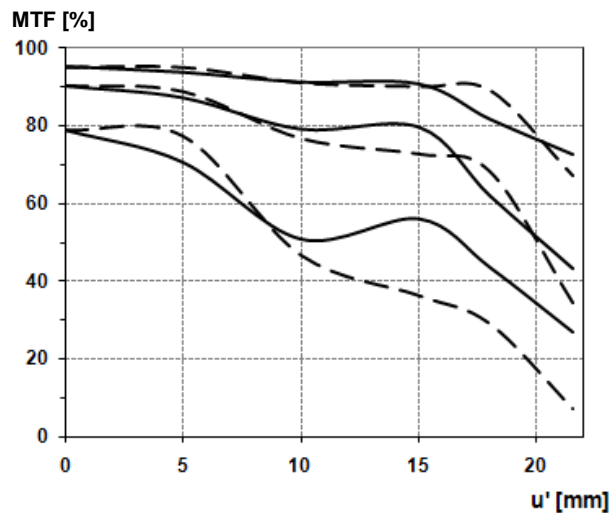

Modulation transfer MTF as a function of the image height (u') and slit orientation. White light. Spatial frequencies $R=10, 20$ and 40 cycles/mm.

f-number 2.8
— Saggital
... Tangential

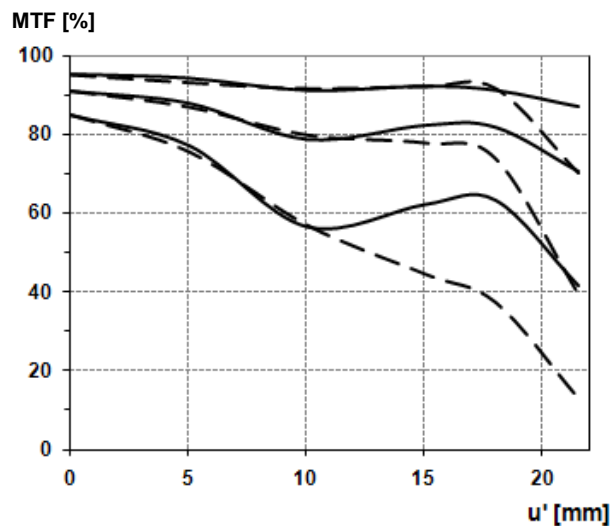

f-number 5.6
— Saggital
... Tangential

*Data for infinite focus setting



ZEISS Interlock 2.8/15

Spectral Transmission

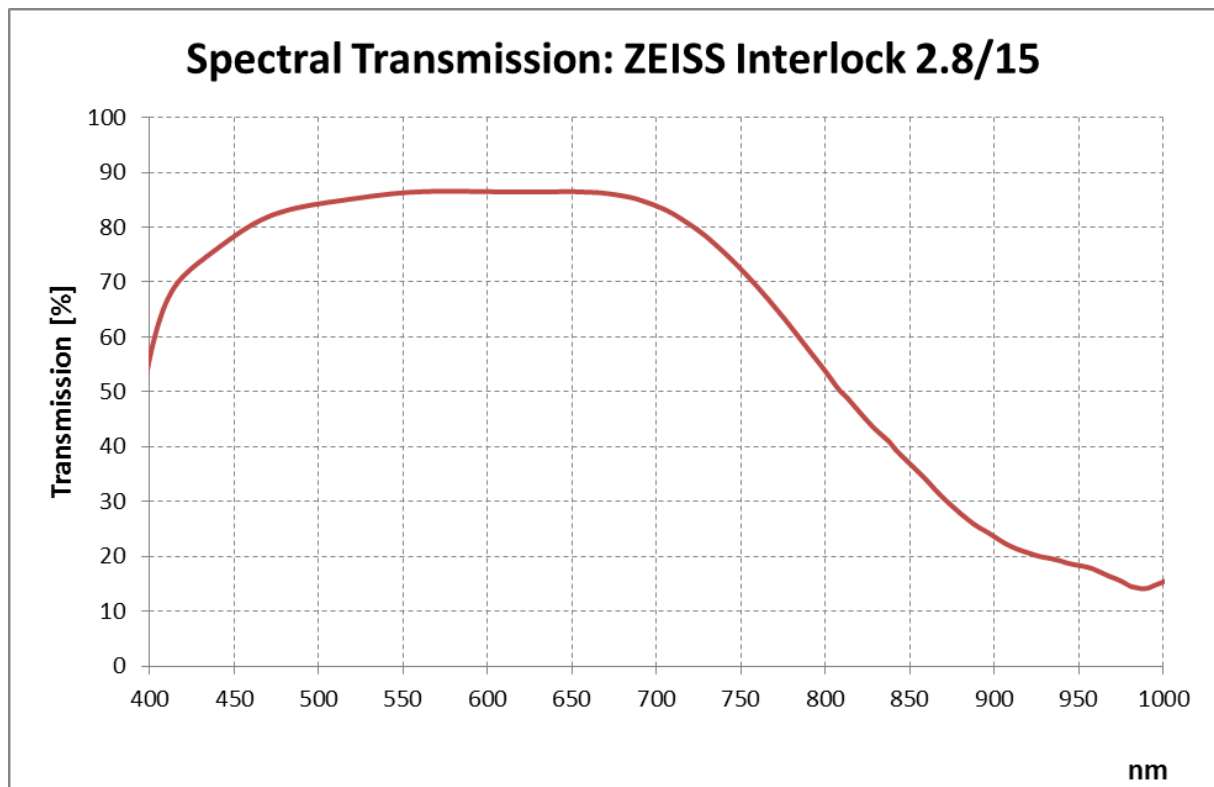



ZEISS Interlock 2.8/15

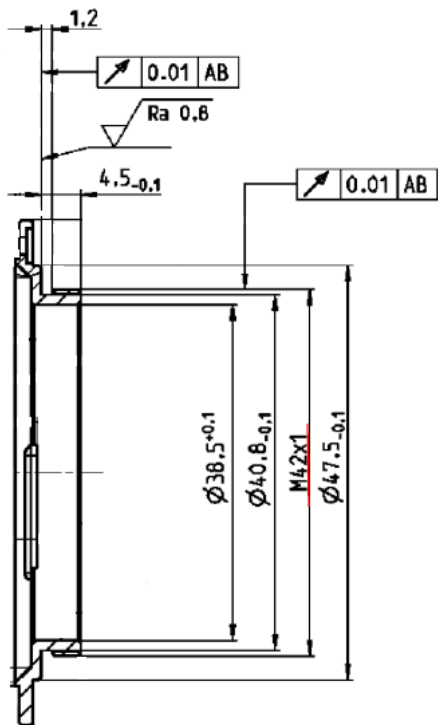

M42 Mount for 45,5 mm Flange Focal Distance

The diameter of the camera/lens adapter must not exceed 55 mm at the lens side!