



ZEISS Distagon T* 2,8/25



Features

- f/2.8 aperture
- Precise manual focusing
- Robust full-metal construction
- Fixation for focus and aperture
- Identical color reproduction of all models
- For industrial cameras with F-Mount up to sensor sizes of 24x36 mm or 43mm line sensors.
- Very short free working distance (60 mm)

ZF-I: Industrial Edition

Features special screws to fix focus and aperture settings even in rough situations.

Camera Mounts

Available with ZF.2 and M42 mount.



ZEISS Distagon T* 2,8/25

Relative Illuminance*

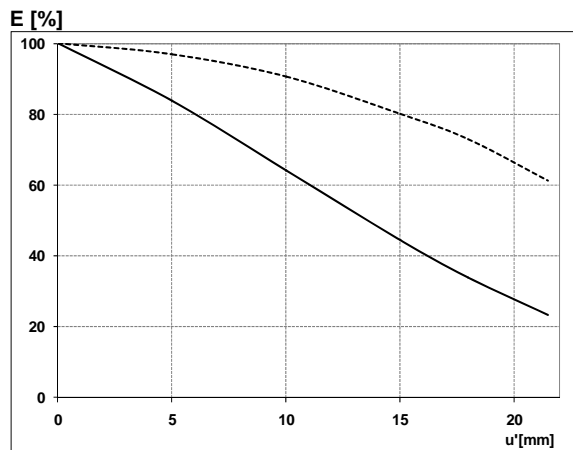

The relative illuminance shows the decrease in image brightness from the image center to the edge in percent.

— f-number 2.8
... f-number 5.6

Relative Distortion*

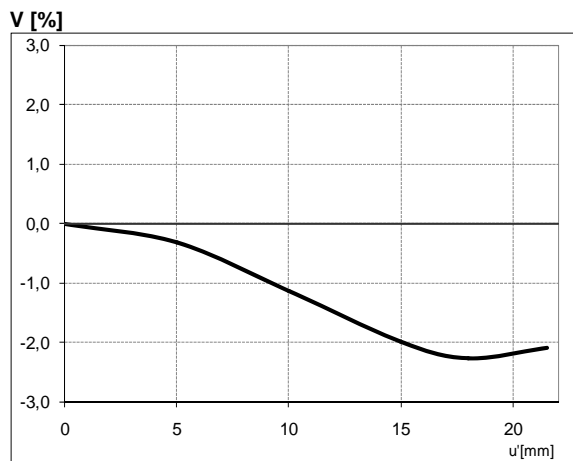

The relative distortion shows the deviation of the actual image height from the ideal one in percent.

**Data for infinite focus setting*



ZEISS Distagon T* 2,8/25

MTF Charts*

MTF [%] k=2.8

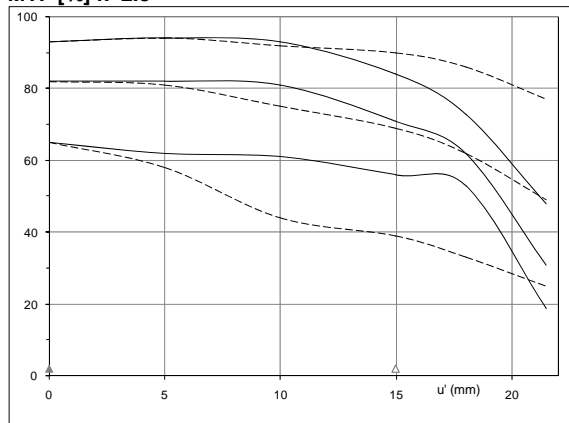

The Modulation Transfer (MTF) as a function of image height (u) and slit orientation (sagittal, tangential) has been measured with white light at spatial frequencies of R = 10, 20 and 40 cycles/mm. The MTF charts are valid for the ZF, ZF-I version and for white light.

f-number 2.8
— Saggital
... Tangential

MTF [%] k=5.6

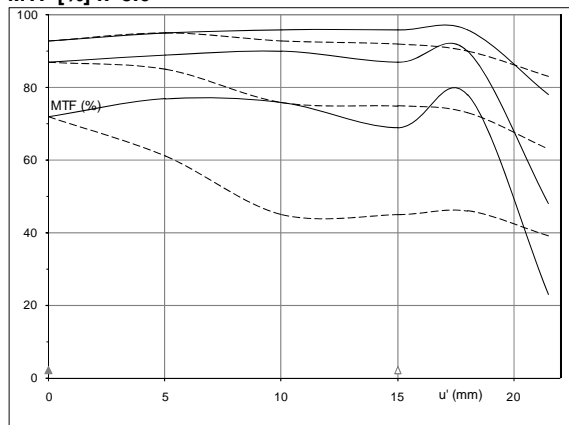

f-number 5.6
— Saggital
... Tangential

*Data for infinite focus setting / Not for IR version



ZEISS Distagon T* 2,8/25

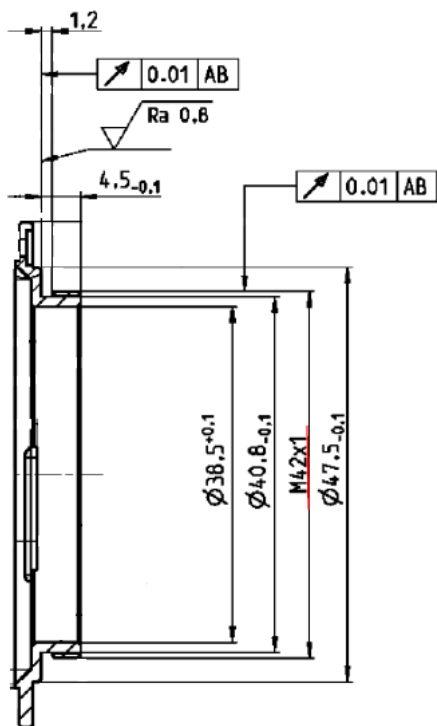

M42 Mount for 45,5 mm Flange Focal Distance

The diameter of the camera/lens adapter must not exceed 55 mm at the lens side!