

Xenon-RUBY Lens

Xenon-RUBY 2.3/16

The Xenon-Ruby lens is optimized in accordance with the sensitivity of modern image sensors up to 1 / 1.8" (9mm). This lens is the perfect trade-off between price and performance: By having a practice-oriented speed of 2.3, a very high optical performance is achieved.

Even under production and / or extreme conditions, the robust mechanical design with lockable focus and iris setting mechanism guarantees reliable continuous use in which the set optical parameters remain in place.



Xenon-RUBY 2.3/16

Key Features

- Robust mechanics for rough industrial environment
- Compact design and low weight
- Focus and iris setting lockable
- High resolution optics
- Transmission 400 - 1000 nm (VIS - NIR)
- Designed for Sensors up to 1 / 1.8" (9mm)

Applications

- Traffic
- Security/Surveillance
- Machine vision and other imaging applications
- Quality control
- Surface inspection
- 2D / 3D Measurement

Technical Specifications

F-stop range	2.3 - 16
Focal length	15.9 mm
Image circle	9 mm
Transmission	400 - 1000 nm
Interface	C-Mount
Filter Thread	M25.5 x 0.5
Weight	60 gr.
Code No.	1074626

Contact

Jos. Schneider Optische Werke GmbH
 Ringstraße 132
 55543 Bad Kreuznach
 Germany
 Phone +49 671 601-205
 Fax +49 671 601-286
<http://www.schneiderkreuznach.com/en/industrial-solutions/>
industrie@schneiderkreuznach.com

Schneider Asia Pacific Ltd.
 20/F Central Tower, 28 Queen's Road
 Central, Hong Kong
 China
 Phone +852 8302 0301
 Fax +852 8302 4722
www.schneider-asiapacific.com
info@schneider-asiapacific.com

Schneider Optics Inc.
 285 Oser Ave.
 Hauppauge, NY 11788
 USA
 Phone +1 631 761-5000
 Fax +1 631 761-5090
www.schneideroptics.com/industrial
industrial@schneideroptics.com

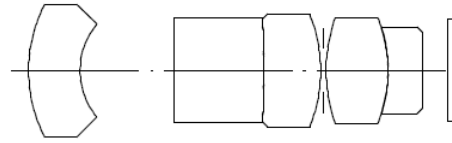
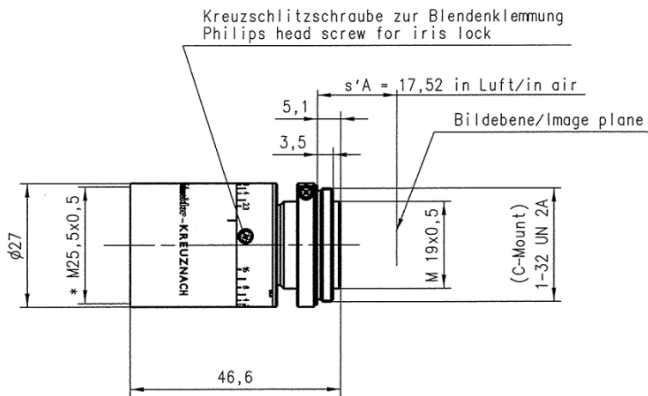

XR 2.3/16

f' = 15.9 mm	β_p = 1.446
s_F = 9.2 mm	s_{EP} = 20.2 mm
s_F^* = 14.1 mm	s_{AP}^* = -8.9 mm
HH' = 16.1 mm	Σd = 42.9 mm

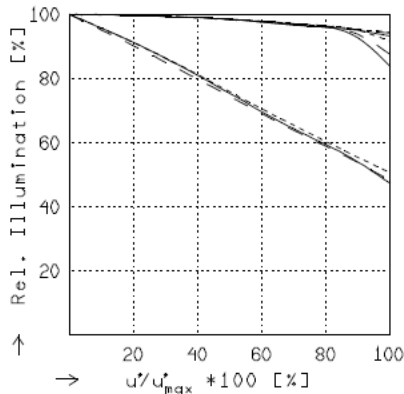

RELATIVE ILLUMINATION

The relative illumination is shown for the given focal distances or magnifications.

	$f / 2.3$	$f / 4.0$	$f / 5.6$
— $\beta' = -0.0200$	$u'_{max} = 4.4$	$00' = 843.$	
- - $\beta' = -0.0500$	$u'_{max} = 4.4$	$00' = 367.$	
..... $\beta' = -0.1000$	$u'_{max} = 4.5$	$00' = 208.$	

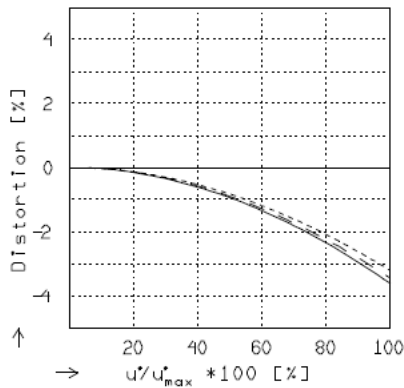

DISTORTION

Distortion is shown for the given focal distances or magnifications. Positive values indicate pincushion distortion and negative values barrel distortion.

— $\beta' = -0.0200$	$u'_{max} = 4.5$	$00' = 843.$
- - $\beta' = -0.0500$	$u'_{max} = 4.5$	$00' = 367.$
..... $\beta' = -0.1000$	$u'_{max} = 4.5$	$00' = 208.$

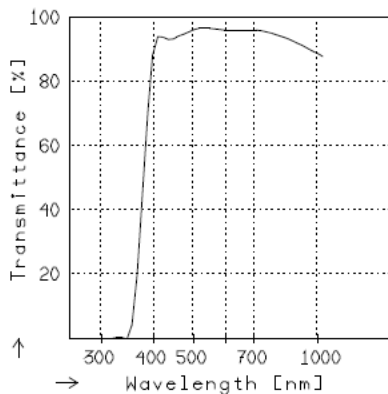

TRANSMITTANCE

Relative spectral transmittance is shown with reference to wavelength.

Xenon-RUBY 2.3/16

XR 2.3/16

MODULATION with reference to the relative image height

Wavelength λ	[nm]	555	655	605	505	455	405
Spectral weighting	[%]	19,8	23,7	22,2	15,7	12,1	6,7
Spatial frequency R	[1/mm]	20	40	80			
Format	[mm X mm]	0.0	9.0				
Diagonal $2u^*$	[mm]		9.0				

radial —
tangential - -

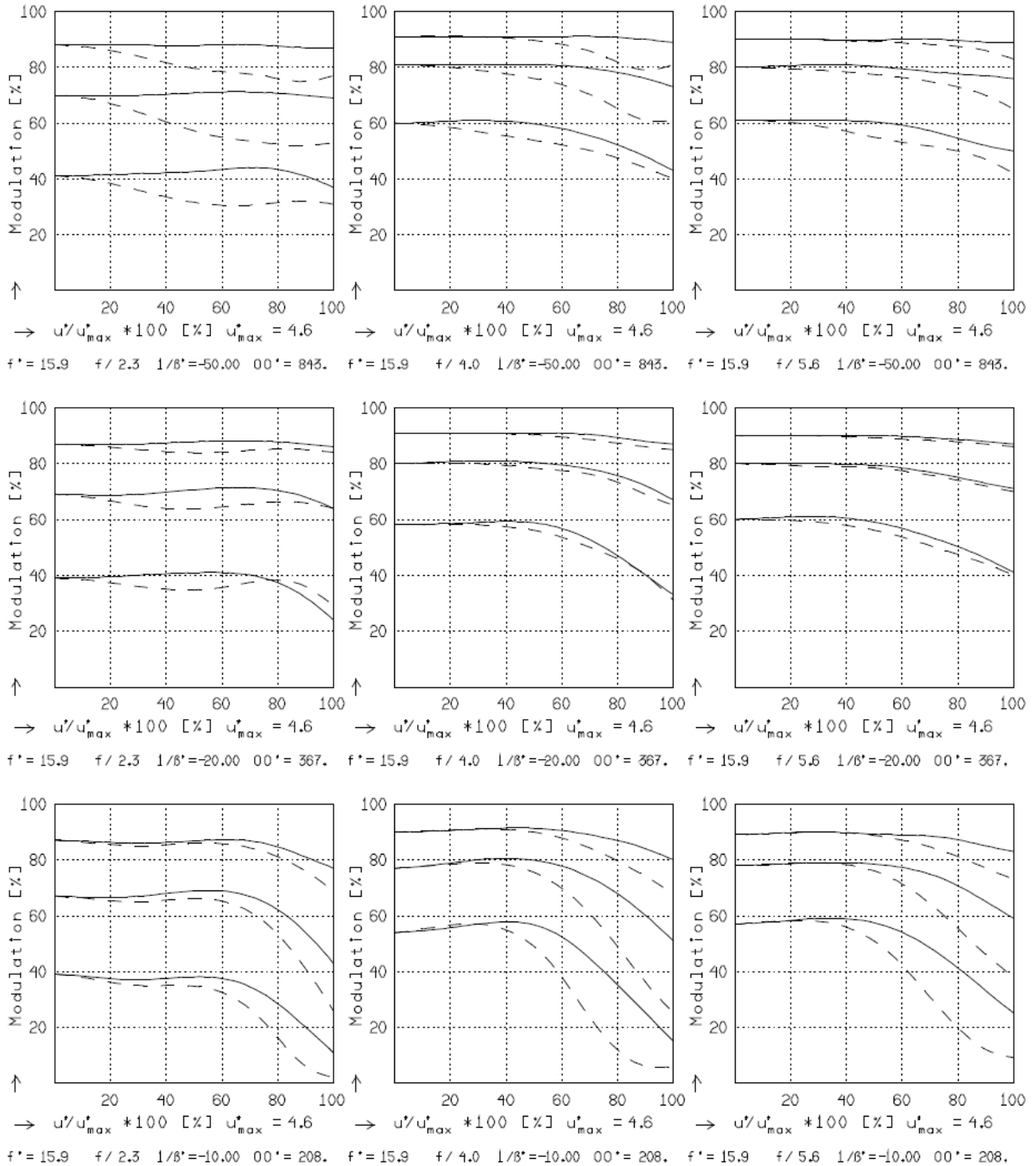

Focusing : MTF_{max} at $f / 2.3$, $R = 80$ 1/mm, $u'/u'_{max} = 0$