



Distagon T* 3,5/18



Features

- f/3.5 aperture
- Precise manual focusing
- Robust full-metal construction
- Identical color reproduction of all models
- For industrial cameras with F-Mount up to sensor sizes of 24x36 mm or 43mm line sensors.
- Super wide angle (99°)

ZF-I: Industrial Edition

Features special screws to fix focus and aperture settings even in rough situations.

Camera Mounts

Available for other camera mounts such as EF, or M42 screw mount.



Distagon T* 3,5/18

Technical Specifications

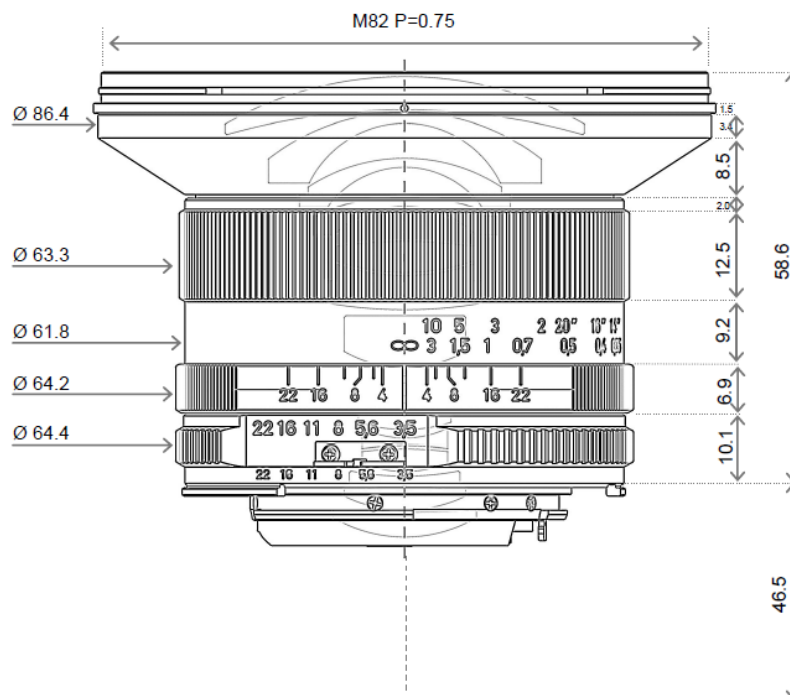

Focal length	18 mm
Aperture range	f/3.5 – f/22 (1/ 2 stop intervals)
Number of elements / groups	13 / 11
Min. working distance (object to sensor)	300 mm (0.98 ft.) – ∞
Min. free working distance	190 mm (0.62 ft.) – ∞
Angular field* (diag. / horiz. / vert.)	99 / 90 / 67°
Max. diameter of image field	43 mm (1.7")
Flange focal length	F-Mount: 46,5 mm (1.8"); M42-Mount: 45,5 mm
Coverage at close range	440 x 290 mm (17.3 x 11.4"), line 559 mm (22")
Image ratio at close range	1:12
Filter-thread	M 82 x 0.75
Weight	470 g (10.94 lbs.)
Camera mount	F bayonet, M42, EF

* referring to 35 mm format



Distagon T* 3,5/18

Relative Illuminance*

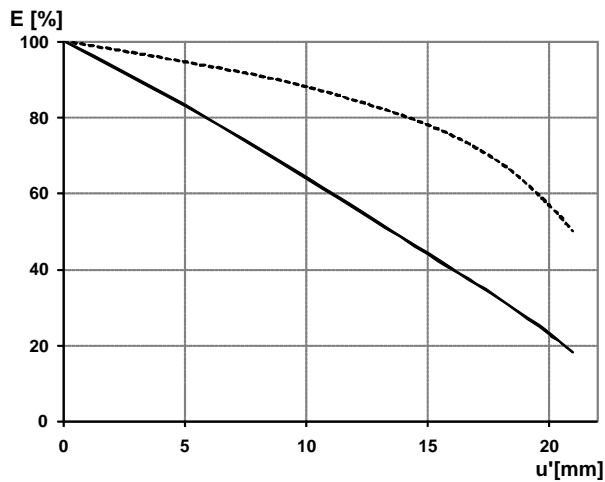

The relative illumination shows the decrease in image brightness from the image center to the edge in percent.

— f-number 3.5
... f-number 8

Relative Distortion*

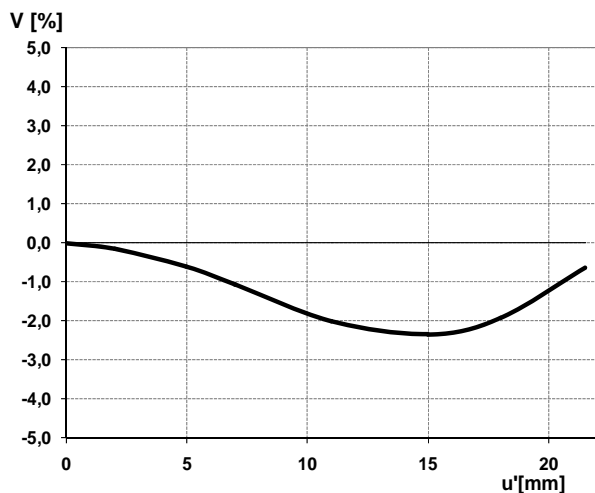

The relative distortion shows the deviation of the actual image height from the ideal one in percent.

*Data for infinite focus setting



Distagon T* 3,5/18

MTF Charts*

MTF [%]

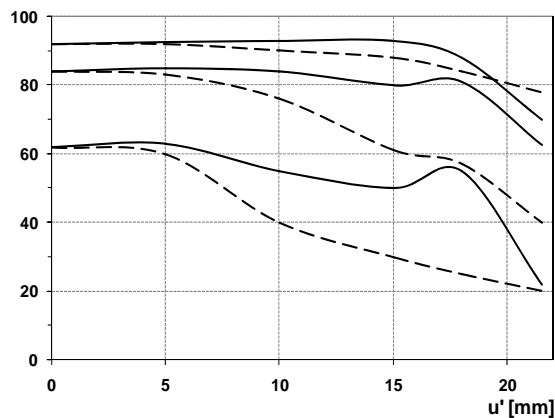

The Modulation Transfer (MTF) as a function of image height (u) and slit orientation (sagittal, tangential) has been measured with white light at spatial frequencies of $R = 10, 20$ and 40 cycles/mm.

f-number 3.5
— Saggital
... Tangential

MTF [%]

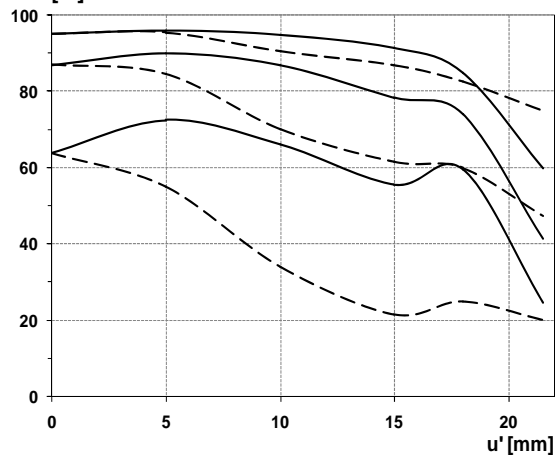

f-number 8
— Saggital
... Tangential

**Data for infinite focus setting*



Distagon T* 3,5/18

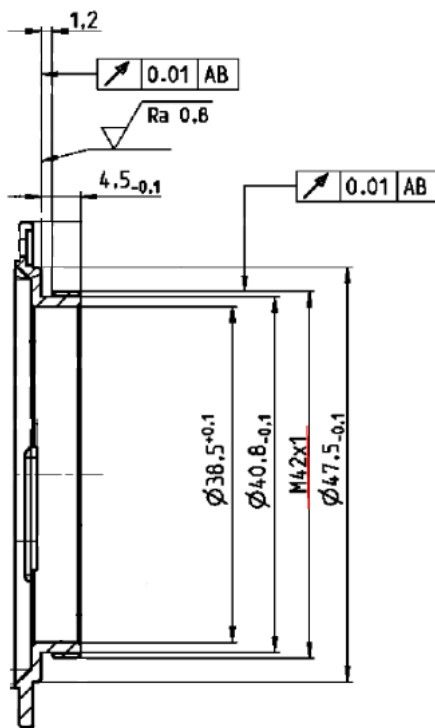

M42 Mount for 45,5 mm Flange Focal Distance

The diameter of the camera/lens adapter must not exceed 55 mm at the lens side!

Authorized Distributor:



Your single source for Imaging Solutions

Ph. 510.657.4000

info@uniforcesales.com

www.uniforcesales.com