



Distagon T* 1,4/35



Features

- Fast f/1.4 aperture
- Precise manual focusing
- Robust full-metal construction
- Identical color reproduction of all models
- For industrial cameras with F-Mount up to sensor sizes of 24x36 mm or 43mm line sensors.

ZF-I: Industrial Edition

Features special screws to fix focus and aperture settings even in rough situations.

Camera Mounts

Available for other camera mounts such as EF, or M42 screw mount.



Distagon T* 1,4/35

Technical Specifications

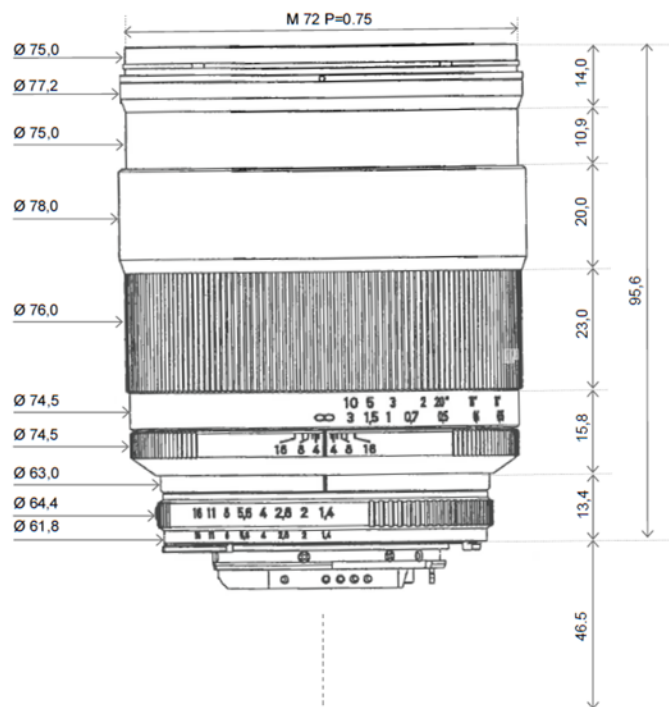

Focal length	35 mm
Aperture range	f/1.4 – f/16 (1/ 2 stop intervals)
Number of elements / groups	11 / 9
Min. working distance (object to sensor)	300 mm (1 ft.) – ∞
Min. free working distance	150 mm (0.5 ft.) – ∞
Angular field* (diag. / horiz. / vert.)	63 / 54 / 37°
Max. diameter of image field	43 mm (1.7")
Flange focal length	F-Mount: 46.5 mm (1.8"); M42-Mount: 45.5 mm
Coverage at close range	120 x 180 mm (4.7 x 7.0"), line 215 mm (8.4")
Image ratio at close range	1:5
Filter-thread	M 72 x 0.75
Weight	830 g (1.83 lbs.)
Camera mount	F bayonet, M42, EF

* referring to 35 mm format



Distagon T* 1,4/35

Relative Illuminance*

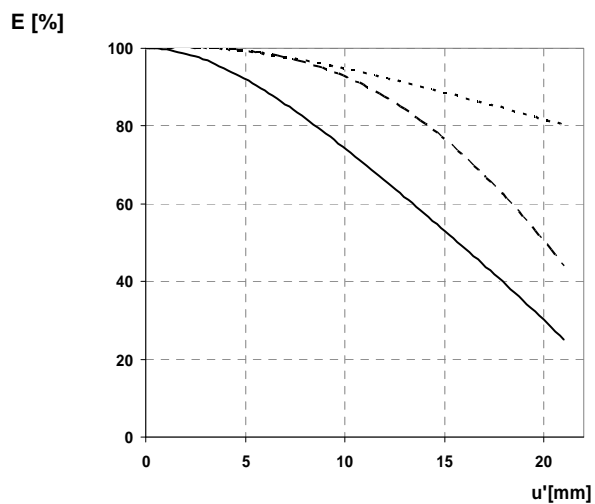

The relative illumination shows the decrease in image brightness from the image center to the edge in percent.

— f-number = 1.4
... f-number = 2.0
--- f-number = 4.0

Relative Distortion*

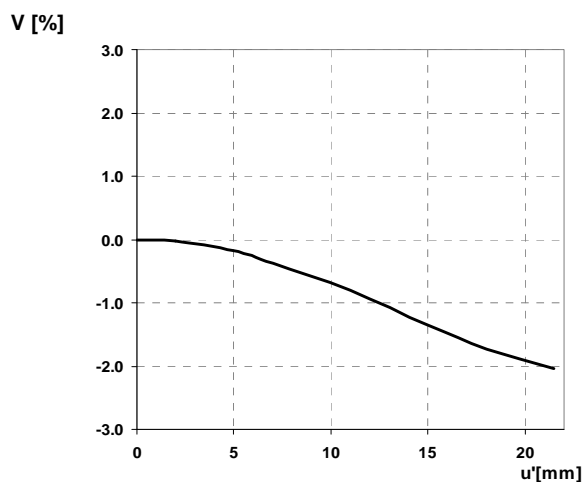

The relative distortion shows the deviation of the actual image height from the ideal one in percent.

*Data for infinite focus setting



Distagon T* 1,4/35

MTF Charts*

MTF [%]

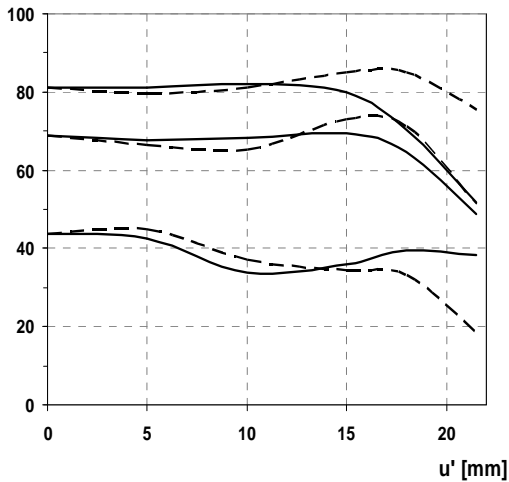

The Modulation Transfer (MTF) as a function of image height (u) and slit orientation (sagittal, tangential) has been measured with white light at spatial frequencies of $R = 10, 20$ and 40 cycles/mm.

f-number = 1.4

— Sagittal
... Tangential

MTF [%]

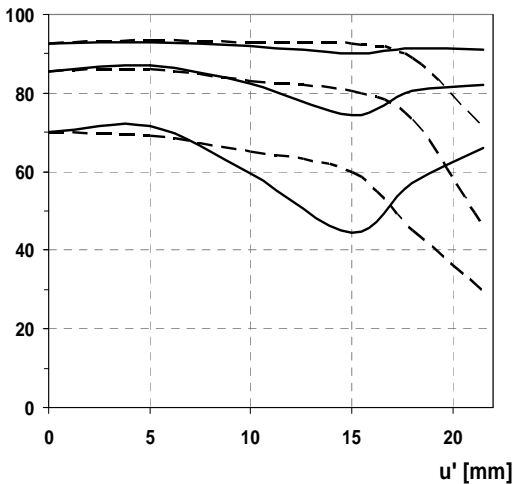

f-number = 4

— Sagittal
... Tangential

*Data for infinite focus setting



Distagon T* 1,4/35

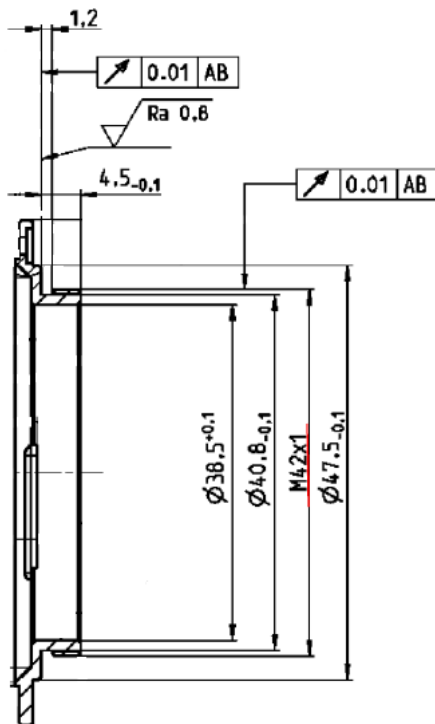

M42 Mount for 45,5 mm Flange Focal Distance

The diameter of the camera/lens adapter must not exceed 55 mm at the lens side!